



**AMERICAN SPECIALTIES, INC.**  
 441 Saw Mill River Road, NY 10701  
 (914) 476.9000 • (914) 476.0688  
 www.americanspecialties.com

**MODEL №: 20200**

**ISSUED: 06/12**

**REVISED: 3 Dec 2012**

**Royal™ Collection TRI-Umph™ High-Speed Hand Dryer (1 of 4)**

**DIMS**  
**INCH [mm]**

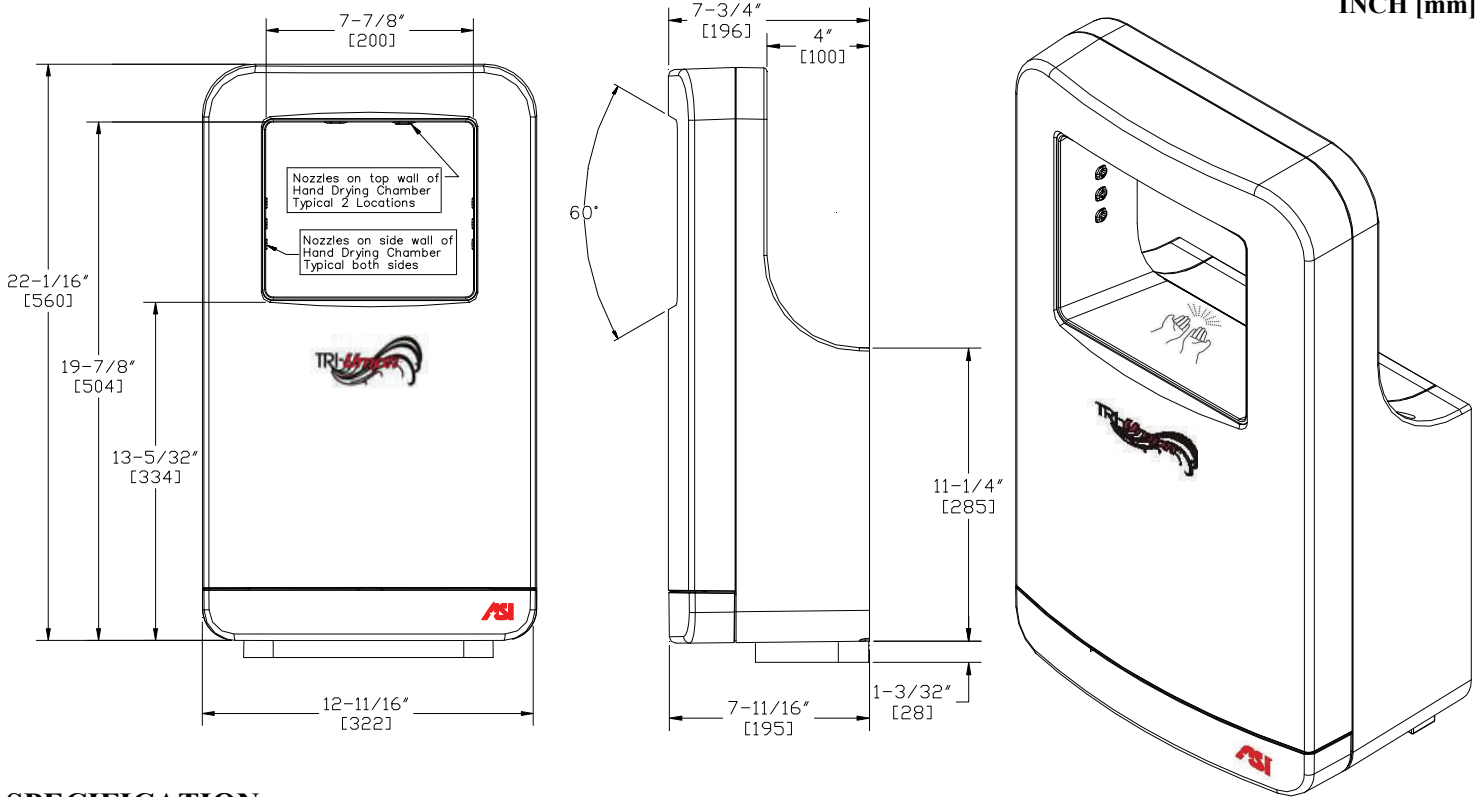

**SPECIFICATION**

Royal™ Collection Surface Mounted Hand Dryer operates automatically from IR sensors that activate dryer when hands are placed in sensor zone. Ready-status LED lights in hand drying chamber turn soothing blue when activated. Cabinet main panel shall be seamless and shall have bowed front face, gently radiused edges and internal reinforcing ribs to provide added strength and complimentary appearance for modern washroom aesthetics and shall be molded in one piece of .06" (1.6) thick ABS. All exposed main panel surfaces shall have a satin finish with appearance of stainless steel. Hand chamber, filter drawer and cabinet back shall be black in same grade. All housing parts shall be permanently treated with antimicrobial Ag+ Ions. Cabinet back steel plates mount flush against wall and shall have concealed pin-hex security screws to retain unit. Motor and heating element shall have internal resetting automatic thermal protection. Fixed directional air nozzles shall be heavy duty, rust proof and tamper resistant. Air intake slots shall not allow access to internal parts. Ceramic water evaporator plate shall be provided integral with cabinet styling. Drip prevention tray shall be provided with drain port for optional waste line (not supplied) concealed mounted under filter drawer. Concealed HEPA antibacterial triple filter (HEPA {H12}, Activated Charcoal and Anti-Microbial layers) will remove particles as small as 0.3 micrometers (0.3 μ-m [Ø 0.0001"]) and shall prevent recycling of contaminated air. Circuitry shall have self-adjusting time-out and fail-safe off protection controlled by a microprocessor that shall detect and reject false signals and shall automatically self calibrate to provide uniform sensitivity over its entire life span. Entire unit shall be internally electrically grounded. Dryer unit shall have CE, C-UL®-US approvals and be listed under the re-examination services of Underwriters Laboratories, Inc. Complete Owner's Manual & Installation Guide (OM & IG) shall be provided with each unit. Unit shall be warranted against defects in materials or workmanship for five (5) years.

**Royal™ Collection Surface Mounted Sensor Hand Dryer shall be Model № 20200-\_\_ (specify model) of American Specialties, Inc., 441 Saw Mill River Road, Yonkers, NY 10701-4913**



**AMERICAN SPECIALTIES, INC.**  
441 Saw Mill River Road, NY 10701  
(914) 476.9000 • (914) 476.0688  
www.americanspecialties.com

**MODEL №: 20200**

**ISSUED: 06/12**

**REVISED: 3 Dec 2012**

## **Royal™ Collection TRI-Umph™ High-Speed Hand Dryer (2 of 4)**

### **INSTALLATION**

Mount unit cabinet on wall with eight (8) № 10 x 1-1/4" (M5) pan head screws (supplied) through wall plate (provided) into plastic anchors (supplied) or other suitably prepared mountings (by others) or other suitable mounting hardware (by others) to suit wall conditions. Electrical service (see rating per model; provided by others) is either provided to duplex outlet in wall adjacent to unit mounting location or brought to KO location for dryer indicated on diagram prior to installation of unit. Electrical service is supplied and connected (by others) in accordance with schematic and Owner's Manual provided with unit prior to installing access drawer. Cabinet is secured first to wall plate with a concealed pin-hex socket pan head security screw (supplied) and then filter drawer is secured also with a concealed pin-hex socket pan head security screw (supplied). For compliance with ICC/ANSI A-117.1 and 2010 ADA Accessibility Standards install unit with top of dryer hand chamber less than 46-3/4" (1187) above finished floor (MAX AFF). For general utility install unit so that top of dryer hand chamber is 44" to 50" (1118 to 1270) AFF. For installation of two or more dryers, units should be no closer than 24" (610) on center. See OM & IG for additional mounting heights for age specific sites.

### **OPERATION**

User activates dryer by placing hands into open hand chamber. LED's change color from amber ready-status to soothing blue to indicate operation. Directional air jets from three (3) sides blow water droplets off hands onto evaporator plate. Dryer automatically shuts off after time-out (Hold-On) when user removes hands from sensor zone or after 60 seconds if unit is purposefully kept operating for longer than normal drying time (e.g. washroom experimentation, vandalism). Owner may choose to set heater on or off with concealed switch for increased economy based upon 450 Watt operating reduction or may choose to vary/reduce heat output with concealed control between 300 Watts and 450 Watts for user comfort level. Evaporator plate allows atomized droplets to return to vapor state without dripping on floor or back wall behind and below unit. Drip tray prevents excessive waste water from draining onto floor under unit in very heavy usage settings or in high-humidity environments. Security locking screw concealed under filter access drawer prevents unauthorized tampering and protects asset. Triple-Filter element removes airborne solid particles and is changed manually by owner on normal periodic cycle determined by maintenance requirements. Replacement filters are available from ASI either in carton quantities or in single units. Motor brushes will require replacement under normal intermittent usage conditions approximately every three to four (3~4) years. Complete operating instructions and maintenance information is provided in OM & IG provided with unit.



**AMERICAN SPECIALTIES, INC.**  
 441 Saw Mill River Road, NY 10701  
 (914) 476.9000 • (914) 476.0688  
 www.americanspecialties.com

**MODEL №: 20200**

**ISSUED: 06/12**

**REVISED: 3 Dec 2012**

**Royal™ Collection TRI-Umph™ High-Speed Hand Dryer (3 of 4)**

**RATINGS**

MODEL	TYPE	TIMING	VOLTS • HERTZ	AMPS	WATTS	IP/Isolation
20200-1	Hand	Automatic 1 second Hold-On with auto 60 sec shutoff	110~120 • 50/60	10.0	1200	Object & Spray proof 23 Class 1
20200-2			208~240 • 50/60	5.0	1200	
20200-3			277 • 60	5.0	1200	

FILTER TYPE	MOTOR	H/P	RPM	FAN TYPE	HEATING ELEMENT	AIR FLOW	TEMP OUTPUT
Triple Layer HEPA Carbon Anti-Bacterial	Brush Type Dual Ball Bearings  Owner choice speed control	1	20 k MAX	Single Inlet Centrifugal with Patented Directional Nozzle Flow Control	Owner Selectable function On-Off switch  450 Watt Nichrome wire with auto reset circuit breaker	55-76 CFM  89-124 m <sup>3</sup> /h	122° F ± 5° (50° C ± 2.8°) MAX  @ 77° F (25° C) ambient room temp

**ADDITIONAL RATINGS**

SAFETY	SOUND PRESSURE	AIR SPEED	DRYING TIME	SENSOR RANGE	MOTOR Temp	HEATER
C-UL®-US CE	67 to 69.8 dB-A @ 2M	145~224 MPH 213~328 Ft/s 65~100 M/s 234~360 km/h	<b>12 ± 3 SECONDS</b>	4-23/32" ± 3/8" (120 ± 10) Inside Hand Chamber	Safety Off @ 275°F (135°C) @ 203°F (95°C)	Reset On @ 167°F (75°C)  Safety Off @ 185°F (85°C)



**AMERICAN SPECIALTIES, INC.**  
441 Saw Mill River Road, NY 10701  
(914) 476.9000 • (914) 476.0688  
www.americanspecialties.com

**MODEL No: 20200**

**ISSUED: 06/12**

**REVISED: 3 Dec 2012**

## Royal™ Collection TRI-Umph™ High-Speed Hand Dryer (4 of 4)

