

# AutoFaucet®

with "Surround Sensor" Technology

500485  
500484

4" Plate 8" Plate

## Automatic Faucet System

- **Delivering Cost-Effective Customer Delight...** provides the user water ONLY when needed, resulting in reduced water usage and associated costs -- *win-win solution*.
- **World-Class Reliability...** breakthrough "surround sensor" technology (no infrared) senses user from any angle, patented cam gear technology controls water flow and eliminates sticking solenoid valves that cause dripping -- *trouble-free operation*.
- **Ease of Installation...** all mechanical and electrical components are contained in one covered housing for easy installation -- *customer convenience maximized*.
- **Radius™ Touch-Free Technology...** systems won't corrode or fail because our proprietary cam-gear "dry" design keeps all electronics away from water flow. Technical Concepts' exclusive technologies enable our systems to be the most accurate on the market delivering error-free, precise performance and are sophisticated enough to compensate for users and the environment.

### Kit Includes:

- Spout with 1.5 GPM Aerator
- Valve Control Housing
- Cover plate (either 4" or 8")
- Mounting Hardware
- Mixing Valve with filter
- (2) Supply Hoses (3/8" x 3/8" x 12")

### Optional Aerators:

- 401190 0.5 GPM Aerator for water savings
- 401148 2.0 GPM Aerator for hard water
- 490137 Extension hose for lowering Valve Control Housing

### Specifications

- Auto/Open Valve Dial: **AUTO-** enables automatic operation of valve.  
**OPEN-** maintains open valve position for sanitary flushing. To reactivate automatic operation, turn dial to auto position and then place hand under faucet and remove.
- Battery Power: 4D cell Alkaline (up to 3+ years life cycle)
- Mounting Hole: 7/8" to 1 1/8"
- Operating Water Pressure: 7-175 psi
- Operating Temperature: 35°F to 159°F (2°C to 70°C)
- Max Running Time: 30 Seconds

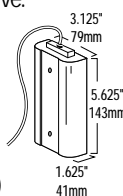

### Operations

- 1) "Surround Sensors" continuously scan the detection zone around the spout.
- 2) When the user's hands come into range of the sensor's detection zone, the valve is activated.
- 3) After the user removes their hands, the valve closes. The circuit automatically resets for the next user.
- 4) Sensors will only detect living beings.

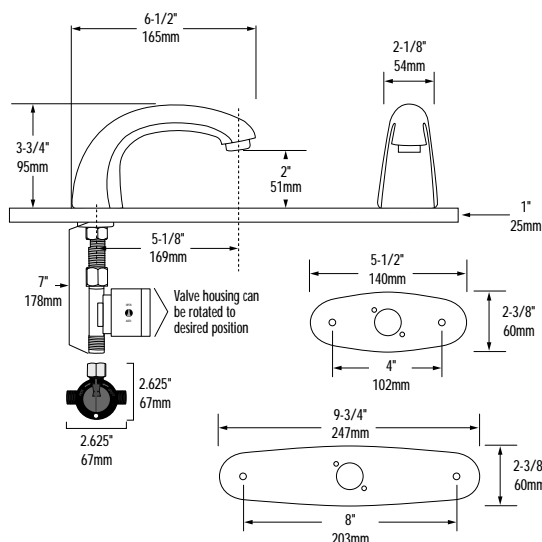

Case Pack: 1  
Case Weight: 7 lbs.  
Case Cube: 2.6

*Air Delights*  
www.airdelights.com

9974 SW Arctic Dr  
Beaverton, OR 97005  
Toll Free: 1-800-440-5556  
Fax: 503-643-8224

