

SF-2100/SF-2150

SF-2200/SF-2250

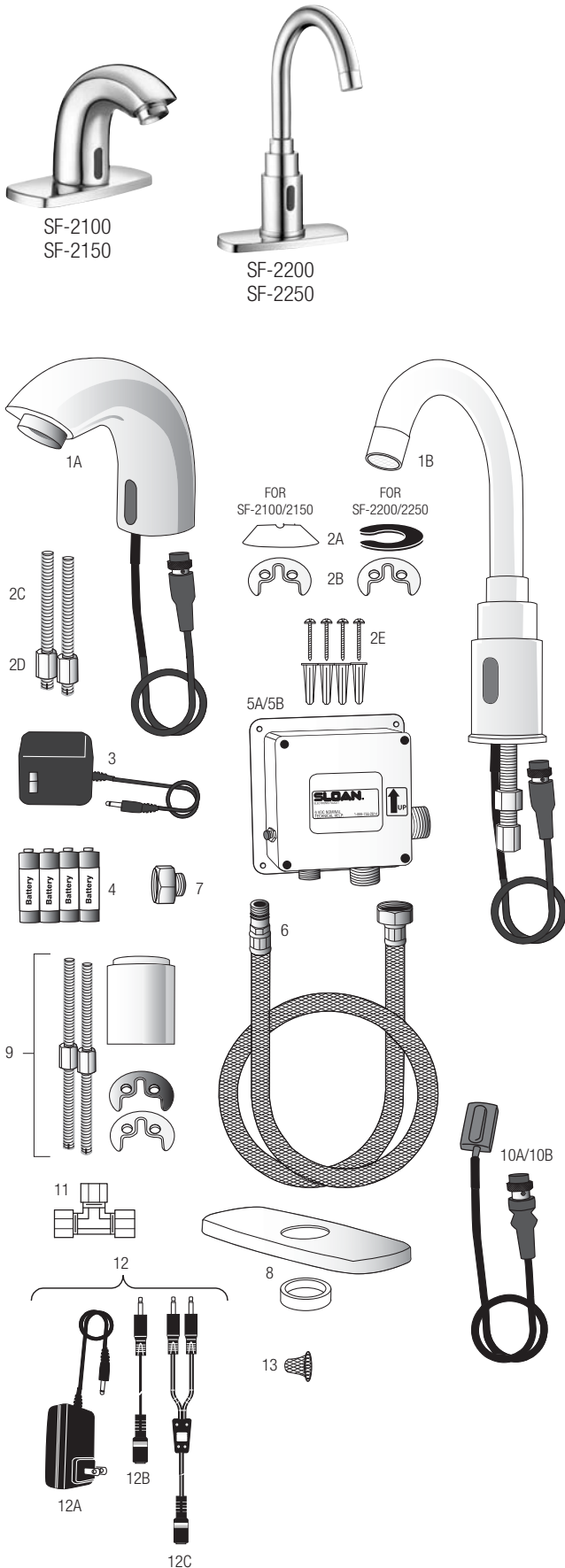

PARTS LIST—SF-2100/SF-2150/SF-2200/SF-2250

Item No.	Code No.	Part No.	Description
1A.	—	—	Pedestal Faucet Assembly w/Outlet (Models SF-2100 and SF-2150)
1B.	—	—	Gooseneck Faucet Assembly w/Outlet (Models SF-2200 and SF-2250)
—	0362004	SFP-4	Mounting Hardware Kit, Pedestal Faucet (Models SF-2100/SF-2150): includes Items 2A, 2B, 2C, 2D and 2E
—	0362005	SFP-5	Mounting Hardware Kit, Gooseneck Faucet (Models SF-2200/2250): includes Items 2A, 2B and 2E
2A.	—	—	Gasket
2B.	—	—	Metal Retainer
2C.	—	—	Threaded Studs (Models SF-2100/2150)
2D.	—	—	Retainer Nuts (Models SF-2100/2150)
2E.	—	—	Screws and Anchors for Control Module (all models)
3.	0362006	SFP-6	110 VAC/6 VDC Plug-In Adapter (US) (Models SF-2100 and SF-2200)
4.	—	—	Batteries, 4 AA-size (all models)
5A.	0362040	SFP-40-A	Control Module with Adjustable Button (6 pin connector)
5B.	0362008	SFP-8	Control Module (Old Style 4 pin connector)*
6.	0362010	SFP-10	Flex Hose, Control Module to Spout (all models)
7.	—	—	Inlet adapter – 1/2" NPSM to 3/8" Compression Connection (not supplied with most international models)
8.	0362011	SFP-11	4" Trim Plate with Spacer (all models)
9.	0362030	SFP-30A	Faucet Extension Kit (Models SF-2100/2150)
10A.	0362041	SFP-41-A	Sensor Assembly (6 pin connector)
10B.	0362034	SFP-34	Sensor Assembly (Old Style 4 pin connector)*
11.	3365461	ETF-617-A	3/8" Bak-Chek® Tee Compression Fitting

* IMPORTANT: Sloan added the range adjustment feature in August 2008 for faucets made prior to August 2008 use the following replacement parts: SFP-34 and SFP-8

NOT SHOWN SEPARATELY

—	0362012	SFP-12	Gooseneck Spout w/Outlet (Models SF-2200/2250)
—	0362014	SFP-14	Spray Head for Gooseneck Faucet (Models SF-2200/2250)
—	0362013	SFP-13	0.5 gpm/1.9 Lpm Spray head (Models: SF-2100/2150)
—	0335012	EAF-15	0.5 gpm/1.9 vandal resistant spray head (Models: SF-2100/2150)
—	0362023	SFP-23	2.2 gpm/8.3 Lpm Aerator (Models: SF-2100/2150)
—	0362024	SFP-24	2.2 gpm/8.3 Lpm vandal resistant aerator (Models: SF-2100/2150)
—	0362020	SFP-26	220 VAC/6 VDC Plug-In Adapter (ASIA)
—	0362025	SFP-25	220 VAC/6 VDC Plug-In Adapter (EURO)
—	0362026	SFP-20	220 VAC/6 VDC Plug-In Adapter (UK)
—	3362022	SFP-22-A	8" Trim Plate

ACCESSORIES

12.	0362035	SFP-35-A	100-240 VAC/6 VDC Gang Adapter Kit, includes 12A, 12B and 12C
12A.	0362016	SFP-36-A	100-240 VAC/6 VDC Plug-In Adapter
12B.	0362018	SFP-38	Cable Splitter, 51"/1300 mm (5 included in kit)
12C.	0362017	SFP-37	Cable Extension, 51"/1300 mm

REPAIR PARTS

13.	0362015	SFP-15	Strainer (located in water inlet of control module)
-----	----------------	--------	---

— in Item No. column = Not shown in illustration
 — in Code No. and Part No. column = Not sold separately

Hand Hygiene

SF-2100/SF-2150**SF-2200/SF-2250****TROUBLESHOOTING GUIDE****1. Faucet delivers water in an uncontrolled manner.**

- A. Faucet is not working properly.
Contact the Sloan Valve Company Installation Engineering Department at 1-888-SLOAN-14 (1-888-756-2614).

2. Faucet does not deliver any water when Sensor is activated.

INDICATOR: Solenoid valve produces an audible “CLICK.”

- A. Water supply stop(s) closed. Open water supply stop(s).
B. Water strainer in control module is clogged. Close supply stops and remove water inlet line at control module. Remove, clean and reinstall strainer and water inlet line. Replace strainer if required.

INDICATOR: Solenoid valve DOES NOT produce an audible “CLICK.”

- A. Batteries low (battery powered models). Replace batteries.
B. Power failure (transformer powered models). Check power supply.

3. Faucet delivers only a slow flow or dribble when Sensor is activated.

- A. Water supply stop(s) are partially closed. Completely open water supply stop(s).
B. Water strainer in control module is clogged. Close supply stops and remove water inlet line at control module. Remove, clean and reinstall strainer and water inlet line. Replace strainer if required.
C. Aerator is clogged. Remove, clean, and reinstall aerator. Replace aerator if required.
D. Faucet is not working properly.
Contact the Sloan Valve Company Installation Engineering Department at 1-888-SLOAN-14 (1-888-756-2614).

4. Faucet does not stop delivering water or continues to drip after user is no longer detected.

- A. Faucet is not working properly.
Contact the Sloan Valve Company Installation Engineering Department at 1-888-SLOAN-14 (1-888-756-2614).

5. The water temperature is too hot or too cold on a Faucet connected to hot and cold supply lines.

- A. Supply Stops are not adjusted properly. Adjust Supply Stops.

CARE AND CLEANING INSTRUCTIONS

DO NOT use abrasive or chemical cleaners (including chlorine bleach) to clean faucet that may dull the luster and attack the chrome or special decorative finishes. Use ONLY mild soap and water, then wipe dry with clean cloth or towel. While cleaning the bathroom tile, protect the faucet from any splattering of cleaner. Acids and cleaning fluids will discolor or remove chrome plating.

**When assistance is required, please contact
Sloan Valve Company Installation Engineering
Department at: 1-888-SLOAN-14 (1-888-756-2614).**

SF-2300/SF-2350

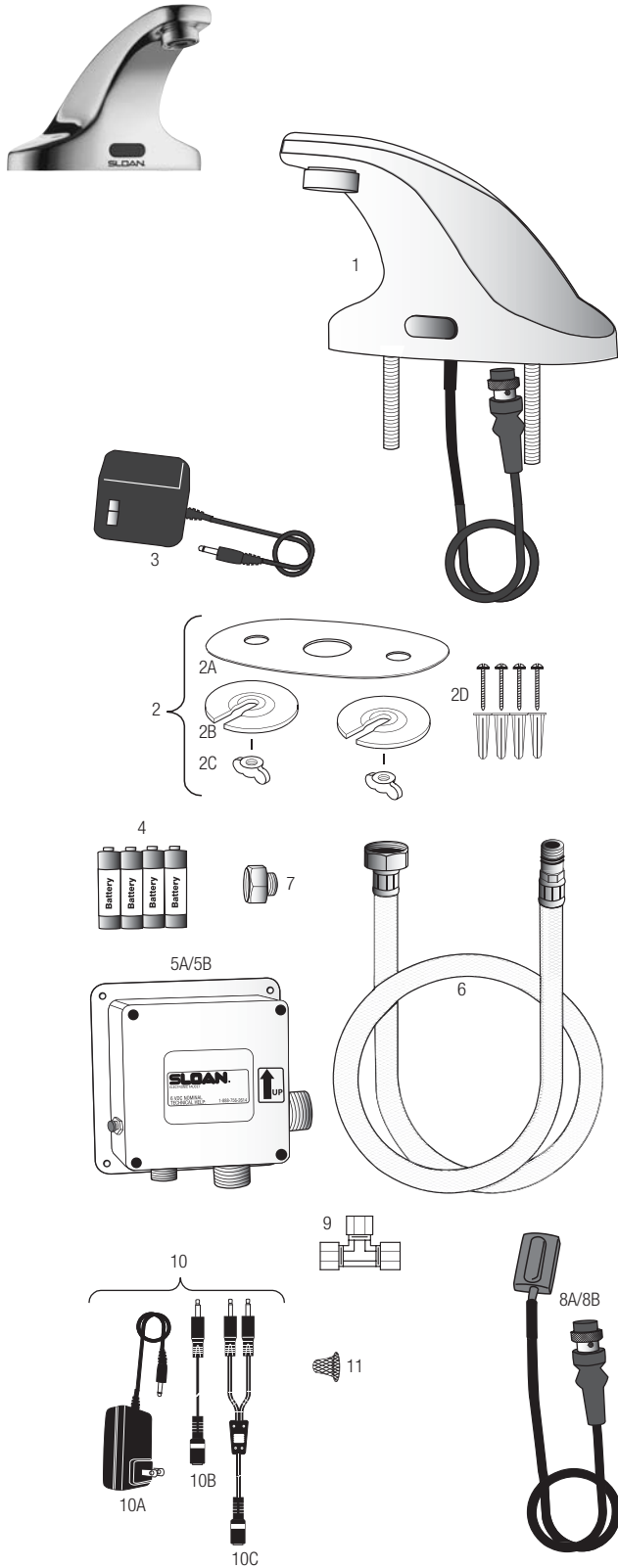

PARTS LIST—SF-2300/SF-2350

Item No.	Code No.	Part No.	Description
1.	—	—	Faucet Assembly w/Outlet
2.	—	SFP-16	Mounting Hardware Kit: includes Items 2A, 2B, 2C and 2D
2A.	—	—	Compression Fitting
2B.	—	—	Washers (2)
2C.	—	—	Wing Nuts (2)
2D.	—	—	Screws and Anchors for Control Module
3.	0362006	SFP-6	110 VAC/6 VDC Plug-In Adapter (US) (Model SF-2300 only)
4.	—	—	Batteries, 4 AA-size (all models)
5A.	0362040	SFP-40-A	Control Module with Adjustable Button (6 pin connector)
5B.	0362008	SFP-8	Control Module (Old Style 4 pin connector)*
6.	0362010	SFP-10	Flex Hose, Control Module to Spout
7.	—	—	Inlet adapter – 1/2" NPSM to 3/8" Compression Connection (not supplied with most international models)

8A.	0362041	SFP-41-A	Sensor Assembly (6 pin connector)
8B.	0362034	SFP-34	Sensor Assembly (Old Style 4 pin connector)*
9.	3365461	ETF-617-A	3/8" Bak-Chek® Tee Compression Fitting

* IMPORTANT: Sloan added the range adjustment feature in August 2008 for faucets made prior to August 2008 use the following replacement parts: SFP-34 and SFP-8

NOT SHOWN SEPARATELY

—	0362013	SFP-13	0.5 gpm/1.9 Lpm Spray head
—	0335012	EAJ-15	0.5 gpm/1.9 vandal resistant spray head
—	0362023	SFP-23	2.2 gpm/8.3 Lpm Aerator
—	0362024	SFP-24	2.2 gpm/8.3 Lpm vandal resistant aerator
—	0362020	SFP-26	220 VAC/6 VDC Plug-In Adapter (ASIA)
—	0362025	SFP-25	220 VAC/6 VDC Plug-In Adapter (EURO)
—	0362026	SFP-20	220 VAC/6 VDC Plug-In Adapter (UK)

ACCESSORIES

10.	0362035	SFP-35-A	100-240 VAC/6 VDC Gang Adapter Kit, includes 10A, 10B and 10C
10A.	0362016	SFP-36-A	100-240 VAC/6 VDC Plug-In Adapter
10B.	0362018	SFP-38	Cable Splitter, 51"/1300 mm (5 included in kit)
10C.	0362017	SFP-37	Cable Extension, 51"/1300 mm

REPAIR PARTS

11.	0362015	SFP-15	Strainer (located in water inlet of control module)
-----	----------------	--------	---

— in Item No. column = Not shown in illustration
 — in Code No. and Part No. column = Not sold separately

Hand Hygiene

SF-2300/SF-2350

TROUBLESHOOTING GUIDE**1. Faucet delivers water in an uncontrolled manner.**

- A. Faucet is not working properly.
Contact the Sloan Valve Company Installation Engineering Department at 1-888-SLOAN-14 (1-888-756-2614).

2. Faucet does not deliver any water when Sensor is activated.

INDICATOR: Solenoid valve produces an audible “CLICK.”

- A. Water supply stop(s) closed. Open water supply stop(s).
B. Water strainer in control module is clogged. Close supply stops and remove water inlet line at control module. Remove, clean and reinstall strainer and water inlet line. Replace strainer if required.

INDICATOR: Solenoid valve DOES NOT produce an audible “CLICK.”

- A. Batteries low (battery powered models). Replace batteries.
B. Power failure (transformer powered models). Check power supply.

3. Faucet delivers only a slow flow or dribble when Sensor is activated.

- A. Water supply stop(s) are partially closed. Completely open water supply stop(s).
B. Water strainer in control module is clogged. Close supply stops and remove water inlet line at control module. Remove, clean and reinstall strainer and water inlet line. Replace strainer if required.
C. Aerator is clogged. Remove, clean, and reinstall aerator. Replace aerator if required.
D. Faucet is not working properly.
Contact the Sloan Valve Company Installation Engineering Department at 1-888-SLOAN-14 (1-888-756-2614).

4. Faucet does not stop delivering water or continues to drip after user is no longer detected.

- A. Faucet is not working properly.
Contact the Sloan Valve Company Installation Engineering Department at 1-888-SLOAN-14 (1-888-756-2614).

5. The water temperature is too hot or too cold on a Faucet connected to hot and cold supply lines.

- A. Supply Stops are not adjusted properly. Adjust Supply Stops.

CARE AND CLEANING INSTRUCTIONS

DO NOT use abrasive or chemical cleaners (including chlorine bleach) to clean faucet that may dull the luster and attack the chrome or special decorative finishes. Use ONLY mild soap and water, then wipe dry with clean cloth or towel. While cleaning the bathroom tile, protect the faucet from any splattering of cleaner. Acids and cleaning fluids will discolor or remove chrome plating.

**When assistance is required, please contact
Sloan Valve Company Installation Engineering
Department at: 1-888-SLOAN-14 (1-888-756-2614).**

SF-2400/SF-2450

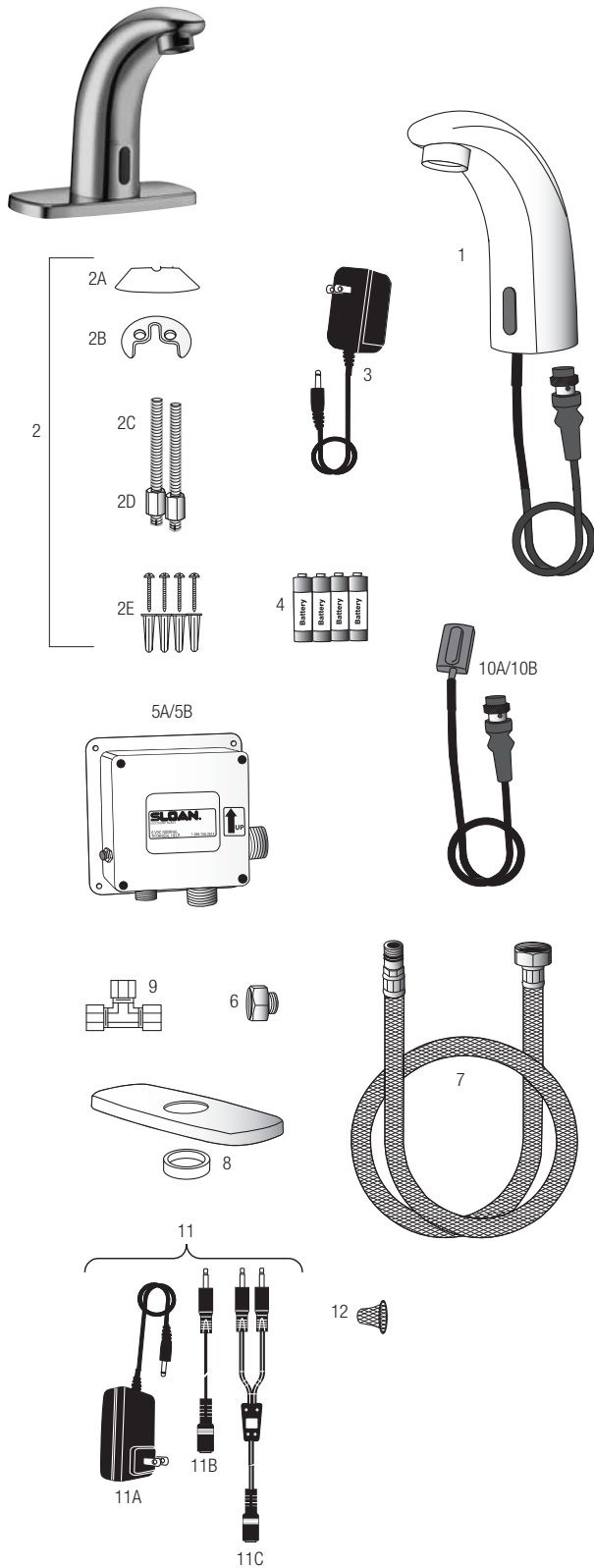

PARTS LIST—SF-2400/SF-2450

Item No.	Code No.	Part No.	Description
1.	—	—	Pedestal Faucet Assembly w/Outlet (Models SF-2400/SF-2450/)
2.	0362004	SFP-4	Mounting Hardware Kit, (Models SF-2100/SF-2150/SF-2400/SF-2450) includes Items: 2A, 2B, 2C, 2D and 2E
2A.	—	—	Beveled Gasket
2B.	—	—	Metal Retainer
2C.	—	—	Threaded Studs (2)
2D.	—	—	Retainer Nuts (2)
2E.	—	—	Screws and Anchors for Control Module
3.	0362006	SFP-6	110 VAC/6 VDC Plug-In Adapter (US)
4.	—	—	Batteries-AA size (4)
5A.	0362040	SFP-40-A	Control Module with Adjustable Button (6 pin connector)
5B.	0362008	SFP-8	Control Module (Old Style 4 pin connector)*
6.	—	—	Inlet adapter – 1/2" NPSM to 3/8" Compression Connection (not supplied with most international models)
7.	0362010	SFP-10	Flex Hose, Control Module to Spout
8.	0362011	SFP-11	Trim Plate w/ Spacer (not supplied with most international models)
9.	3365461	ETF-617-A	3/8" Bak-Chek® Tee Compression Fitting
10A.	0362041	SFP-41-A	Sensor Assembly (6 pin connector)
10B.	0362034	SFP-34	Sensor Assembly (Old Style 4 pin connector)*

* IMPORTANT: Sloan added the range adjustment feature in August 2008 for faucets made prior to August 2008 use the following replacement parts: SFP-34 and SFP-8

NOT SHOWN SEPARATELY

—	0362013	SFP-13	0.5 gpm/1.9 Lpm Spray head
—	0335012	EAF-15	0.5 gpm/1.9 vandal resistant spray head
—	0362023	SFP-23	2.2 gpm/8.3 Lpm Aerator
—	0362024	SFP-24	2.2 gpm/8.3 Lpm vandal resistant aerator
—	0362020	SFP-26	240 VAC/6 VDC Type A Flat Blade (Asia) Plug-in Adapter
—	0362025	SFP-25	240 VAC/6 VDC Type C Round Pin (Euro) Plug-in Adapter
—	0362026	SFP-20	240 VAC/6 VDC Type G Rectangular (UK) Plug-in Adapter
—	0362022	SFP-22	8" Trim Plate

ACCESSORIES

11.	0362035	SFP-35-A	100-240 VAC/6 VDC Gang Adapter Kit, includes 11A, 11B and 11C
11A.	0362016	SFP-36-A	100-240 VAC/6 VDC Plug-In Adapter
11B.	0362018	SFP-38	Cable Splitter, 51"/1300 mm (5 included in kit)
11C.	0362017	SFP-37	Cable Extension, 51"/1300 mm

REPAIR PARTS

12.	0362015	SFP-15	Strainer (located in water inlet of control module)
-----	----------------	--------	---

— in Item No. column = Not shown in illustration
 — in Code No. and Part No. column = Not sold separately

Hand Hygiene

SF-2400/SF-2450

TROUBLESHOOTING GUIDE

1. Faucet delivers water in an uncontrolled manner.

- A. Faucet is not working properly.
Contact the Sloan Valve Company Installation Engineering Department at 1-888-SLOAN-14 (1-888-756-2614).

2. Faucet does not deliver any water when Sensor is activated.

INDICATOR: Solenoid valve produces an audible “CLICK.”

- A. Water supply stop(s) closed. Open water supply stop(s).
B. Water strainer in control module is clogged. Close supply stops and remove water inlet line at control module. Remove, clean and reinstall strainer and water inlet line. Replace strainer if required.

INDICATOR: Solenoid valve DOES NOT produce an audible “CLICK.”

- A. Batteries low (battery powered models). Replace batteries.
B. Power failure (transformer powered models). Check power supply.

3. Faucet delivers only a slow flow or dribble when Sensor is activated.

- A. Water supply stop(s) are partially closed. Completely open water supply stop(s).
B. Water strainer in control module is clogged. Close supply stops and remove water inlet line at control module. Remove, clean and reinstall strainer and water inlet line. Replace strainer if required.
C. Aerator is clogged. Remove, clean, and reinstall aerator. Replace aerator if required.
D. Faucet is not working properly.
Contact the Sloan Valve Company Installation Engineering Department at 1-888-SLOAN-14 (1-888-756-2614).

4. Faucet does not stop delivering water or continues to drip after user is no longer detected.

- A. Faucet is not working properly.
Contact the Sloan Valve Company Installation Engineering Department at 1-888-SLOAN-14 (1-888-756-2614).

5. The water temperature is too hot or too cold on a Faucet connected to hot and cold supply lines.

- A. Supply Stops are not adjusted properly. Adjust Supply Stops.

CARE AND CLEANING INSTRUCTIONS

DO NOT use abrasive or chemical cleaners (including chlorine bleach) to clean faucet that may dull the luster and attack the chrome or special decorative finishes. Use ONLY mild soap and water, then wipe dry with clean cloth or towel. While cleaning the bathroom tile, protect the faucet from any splattering of cleaner. Acids and cleaning fluids will discolor or remove chrome plating.

**When assistance is required, please contact
Sloan Valve Company Installation Engineering
Department at: 1-888-SLOAN-14 (1-888-756-2614).**