

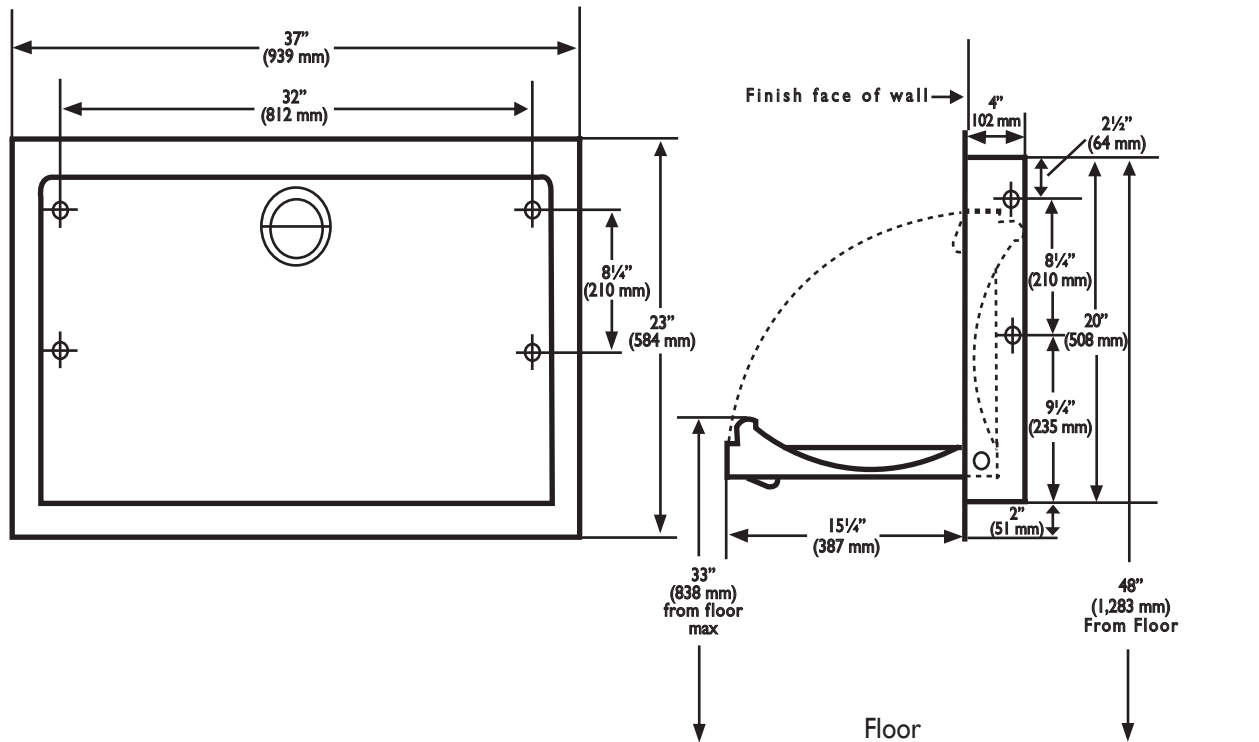

6982 S Quentin St  
Centennial, CO 80112  
Toll free: 888.733.3456  
Main 303.539.8300  
Fax: 303.539.8399  
www.koalabear.com

# HORIZONTAL RECESSED-MOUNTED STAINLESS STEEL BABY CHANGING STATION

## KB110-SSRE



### Rough Wall Opening

**35 1/2" (900mm) wide**  
**20 1/2" (529mm) high**  
**4" (102mm) minimum**  
**recessed depth**



**ADA Compliance**  
(when properly installed)  
4.4.1 Max. Protruding Objects  
4.2.5 Forward Reach  
4.2.6 Side Reach  
4.27.4 Operation

Continued...

## MATERIALS:

18 gauge, type 304 satin stainless steel exterior finish with FDA approved blow molded high-density grey polyethylene with Microban® antimicrobial interior. Reinforced full-length steel-on-steel hinge mechanism, with 11-gauge steel mounting plates and mounting hardware included. Molded in graphics and safety messages in six languages. Contoured changing surface area is 442 sq. in (2873 sq. mm) and comes complete with nylon safety straps and bag hooks.

## OPERATION:

Concealed pneumatic cylinder and hinge structure provides controlled, slow opening and closing of bed. High-density polyethylene is easy to clean and resists odors and bacterial growth. Complies with ASTM static load performance requirements when properly installed. Built-in liner dispenser holds approximately 25 KB150-99 sanitary liners.

**Warning:** To ensure that the unit supports the intended loads, baby changing stations must be properly installed according to the manufacturer's instructions.

## INSTALLATION:

To ensure proper installation and compliance to building codes, it is recommended that a qualified person or carpenter perform the installation of the unit. The unit must be properly installed onto a permanent wall that is capable of supporting significant weight and can accommodate the supplied installation hardware. The Koala Baby Changing Station meets ADA regulations when properly installed.

### Drilling holes and mounting the station:

1. Remove the station from the shipping container and check for any freight damage. Identify the best location for installing the Baby Changing Station. Hold the unit in place, open the bed, and make sure that there is adequate operating clearance.
2. Select the wall area where the Baby Changing Station will be installed. Measure from the floor, at the center of the stud, and mark the wall for the appropriate height. Hold the unit in place to verify alignment. Cut an opening in the wall 35½" (900 mm) wide, 20½" (529 mm) high, 4" (102 mm) minimum depth and install framing on top, bottom and sides of wall opening. If the wall surface is masonry or tile over wood studs, use caution when cutting the hole for the unit.
3. The unit will be mounted using four ¼" x 1½" (108 mm x 38 mm) wood screws through the sides of the unit into the framing of the wall opening.
4. Place the unit into the recessed wall opening and insert the screws and flat washers to hold the Baby Changing Station in place. It may be necessary to adjust the door to square by using a shim on the top right or left side of the unit before tightening securely to the wall.

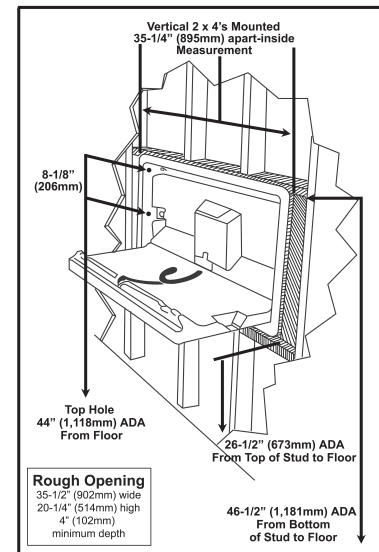

## SPECIFICATION:

Baby changing station body shall have 18 gauge, type 304 satin stainless steel exterior finish with high-density grey polyethylene interior. Design of unit shall be recess-mounted. Unit shall be equipped with a pneumatic cylinder for controlled opening and closing of bed. Bed shall be secured to back plate with a concealed, full-length steel-on-steel hinge. Unit shall have Microban® antimicrobial embedded into plastic material. No hinge structure shall be exposed on interior or exterior surfaces. Unit shall have 11-gauge steel mounting plates with mounting hardware included. Unit shall conform to ANSI S117.1 Accessible and Usable Buildings and Facilities, ASTM F 2285-04 Standard Consumer Safety performance Specification for Diaper Changing Tables for Commercial Use, ANSI Z535.4 Product Safety Signs and Labels, ASTM G21 Antifungal and ASTM G22 Antibacterial Standards or local code if more stringent installation requirements are applicable for barrier-free accessibility. Unit shall comply with ADA regulations when properly installed. Bed shall have smooth concave changing area with a nylon safety strap and two hooks for bags or purses. Unit shall have a built-in Liner Dispenser for use with 3-ply chemical free biodegradable sanitary liners, universal instruction graphics and safety messages in 6 languages. Unit shall be backed by manufacturer's 5-year limited warranty on materials and workmanship, and a 5-year replacement warranty against vandalism. Unit shall be manufactured in the U.S.A.

The illustrations and descriptions herein are applicable to production as of the date of this Technical Data Sheet.

The manufacturer reserves the right to, and does from time to time, make changes and improvements in designs and dimensions without notice.



Koala Kare Products  
A Division of Bobrick

6982 S. Quentin Street  
Centennial, CO 80112-3945

Main: 303.539.8300  
Fax: 303.539.8399

Toll Free: 888.733.3456  
www.koalabear.com