

# Gem•2® Flushometer

Click Product Code No. to Purchase Part

Manual Flushometers

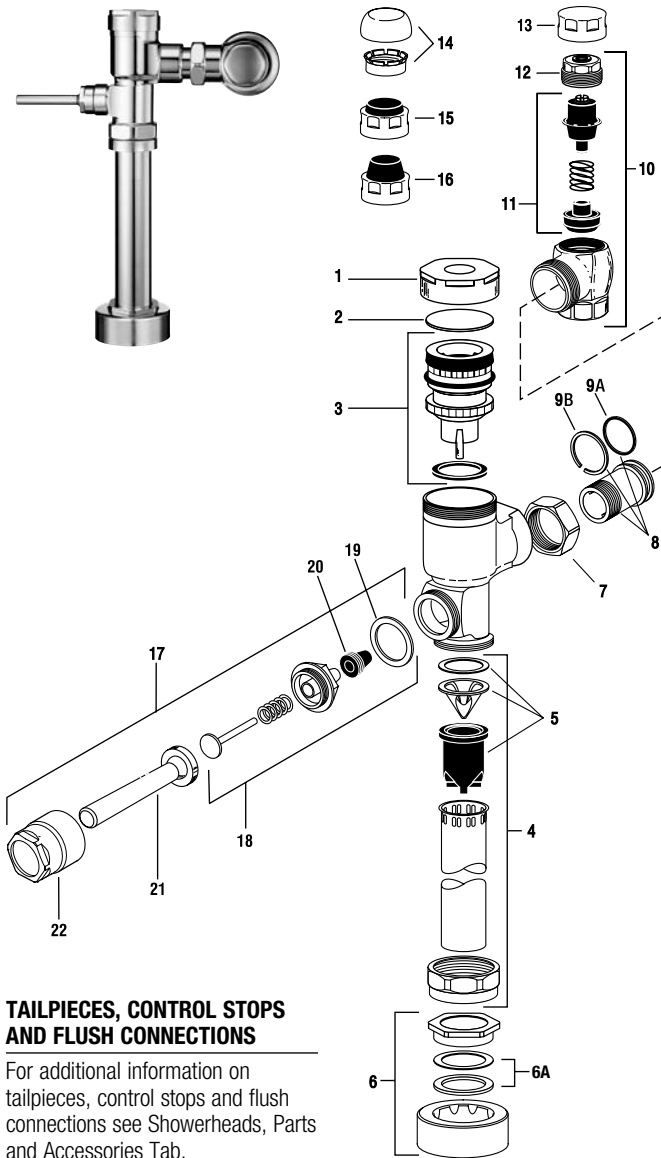

### TAILPIECES, CONTROL STOPS AND FLUSH CONNECTIONS

For additional information on tailpieces, control stops and flush connections see Showerheads, Parts and Accessories Tab.

### PARTS LIST

Item No.	Code No.	Part No.	Description
1.	<a href="#">0307142</a>	G-105	CP Cover
2.	<a href="#">0307139</a>	G-106	Slip Disc
3.	<a href="#">3307135</a>	G-1022-A	Piston Kit – 1.28 gpf/4.8 Lpf Water Closet
	<a href="#">0307193</a>	G-1007-A	Piston Kit – 3.5 gpf/13.2 Lpf Water Closet
	<a href="#">0307195</a>	G-1016-A	Piston Kit – 1.6 gpf/6 Lpf Water Closet
	<a href="#">0307192</a>	G-1009-A	Piston Kit – 1.5 gpf/5.7 Lpf Urinal
	<a href="#">0307185</a>	G-1017-A	Piston Kit – 1.0 gpf/3.8 Lpf Urinal
	<a href="#">3307133</a>	G-1018-A	Piston Kit – 0.5 gpf/1.9 Lpf Urinal
	<a href="#">3307134</a>	G-1019-A	Piston Kit – 2.4 gpf/9.0 Lpf Water Closet

### PISTON KITS FOR OLD STYLE ADJUSTABLE GEM FLUSHMETERS

	<a href="#">0307043</a>	G-1003-A	Piston Kit – Water Closet
	<a href="#">0307044</a>	G-1002-A	Piston Kit – Urinal

### ALL PISTON KITS INCLUDE G-21 MAIN SEAT (See next page)

4.	<a href="#">5323005</a>	V-500-AA	3/4" x 9" Vacuum Breaker – 6 per package
	<a href="#">5323006</a>	V-500-AA	1-1/4" x 9" Vacuum Breaker – 6 per package
	<a href="#">5323007</a>	V-500-AA	1-1/2" x 9" Vacuum Breaker – 6 per package
5.	<a href="#">3323192</a>	V-551-A	Vacuum Breaker Repair Kit
6.	<a href="#">3332002</a>	CR-1010-A	1-1/2" (38 mm) Spud Coupling
	<a href="#">3332001</a>	CR-1009-A	1-1/4" (32 mm) Spud Coupling
	<a href="#">3332000</a>	CR-1008-A	3/4" (19 mm) Spud Coupling

### 6A. SEE SLIP JOINT GASKETS AND RINGS TABLE BELOW LEFT

7.	<a href="#">0308676</a>	H-550	Stop Coupling
8.	<a href="#">0308801</a>	H-551-A	Adjustable Tailpiece 2-1/16" (Standard Length)
9A.	<a href="#">5308696</a>	H-553	O-ring – 24 per package
9B.	<a href="#">5308381</a>	H-552	Locking ring – 12 per package
10.	<a href="#">0388022</a>	H-710-A	1" Screwdriver Bak-Chek® Stop CP – complete
	<a href="#">0388025</a>	H-710-A	3/4" Screwdriver Bak-Chek® Stop CP – complete
11.	<a href="#">3308853</a>	H-541-A	Control Stop Repair Kit*
	<a href="#">3308856</a>	H-543-A	Control Stop Repair Kit**
12.	<a href="#">0308612</a>	H-622	CP Bonnet*
	<a href="#">0308843</a>	H-577	CP Bonnet** – <b>OBSELETE</b>
13.	<a href="#">3308840</a>	H-573-A	Control Stop Cap CP*
	<a href="#">0308848</a>	H-582	Control Stop Cap CP**
14.	<a href="#">3308791</a>	H-1010-A	Vandal Resistant Control Stop Cap Assembly*
	<a href="#">3308790</a>	H-1009-A	Vandal Resistant Control Stop Cap Assembly**
15.	<a href="#">3308866</a>	H-574	Control Stop Cap w/Bumper (-YO Variation)*
16.	<a href="#">3308867</a>	H-576	Control Stop Cap w/Extended Bumper (-YG Variation)*

### HANDLE REPAIR KIT

17.	<a href="#">0307100</a>	G-143	Handle Assembly
18.	<a href="#">5307074</a>	G-50-A	Handle Repair Kit – 6 per package
19.	<a href="#">5307065</a>	G-35	Handle Gasket – 48 per package
20.	<a href="#">5302297</a>	B-39	Handle Seal – 12 per package
21.	<a href="#">0307024</a>	G-145	Handle Grip
22.	<a href="#">0307020</a>	G-144	Handle Socket

\*For use with 1" and 3/4" H-700-A and 1" H-600-A Bak-Chek® screwdriver control stop

\*\*For use with 3/4" H-600-A Bak-Chek® screwdriver control stop

### ITEM 6A. SLIP JOINT GASKETS AND RINGS

Size	Code No.	Part No.	Description
1-1/2"	<a href="#">5306058</a>	F-3	Red Friction Ring
	<a href="#">5322001</a>	VBF-5	Black Slip Joint Gasket
	<a href="#">0319086/5319086</a>	S-30	Flexible Seat
	<a href="#">0319079</a>	S-21	Rigid Seat (rubber over brass)
1-1/2" x 1-1/4"	<a href="#">0396062</a>	F-105	Slip Joint Gasket – Rigid
1-1/4"	<a href="#">5306057</a>	F-3	Red Friction Ring
	<a href="#">5322176</a>	VBF-5	Black Slip Joint Gasket
	<a href="#">0307052/5307052</a>	G-21	Rigid Seat (rubber over brass)
1"	<a href="#">5306056</a>	F-3	Red Friction Ring
	<a href="#">5306115</a>	F-5	Black Slip Joint Gasket
3/4"	<a href="#">5306055</a>	F-3	Red Friction Ring
	<a href="#">5306113</a>	F-5	Black Slip Joint Gasket

# Gem•2® Flushometer

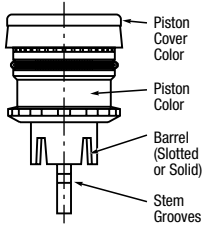

Gem•2 Pistons can be identified by the color, shape and marking of the above components.

### ITEM 3. PISTON KITS

Code No.	Part No.	Description	Cover Color	Piston Color	Barrel	Grooves
<b>0307193</b>	G-1007-A	3.5 gpf (13.2 Lpf) – Water Closet	White	Gray	Slotted	2
<b>0307195</b>	G-1016-A	1.6 gpf (6.0 Lpf) – Water Closet	Green	Black	Slotted	2*
<b>0307192</b>	G-1009-A	1.5 gpf (5.7 Lpf) – Urinal	Black	Black	Solid	2
<b>0307185</b>	G-1017-A	1.0 gpf (3.8 Lpf) – Urinal	Yellow	Black	Solid	1
<b>3307133</b>	G-1018-A	0.5 gpf (1.8 Lpf) – Urinal	Red	Black	Solid	3
<b>3307134</b>	G-1019-A	2.4 gpf (9.0 Lpf) – Water Closet	Blue	Gray	Slotted	0
<b>3307135</b>	G-1022-A	1.28 gpf (4.8 Lpf) – Water Closet	Deep Purple	Black	Slotted	0

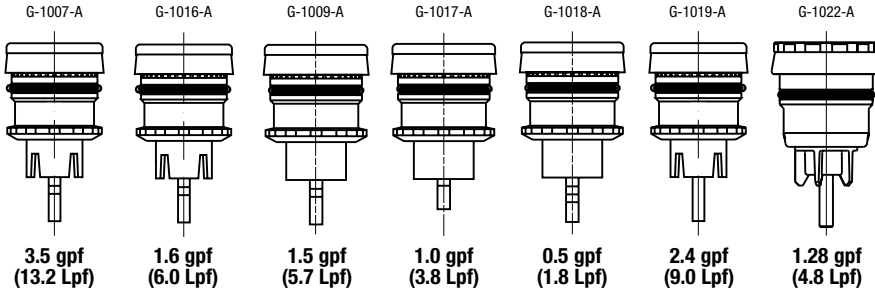

\*Prior to February 2006-1 Groove

### ITEM 3. PISTON COMPONENTS

Item	Code No.	Part No.	Description
A.	***	***	Piston Cover
B.	<b>5307106</b>	G-78	Molded Cup – 12 per package
C.	<b>0307130</b>	G-102	Spring
D.	***	***	Relief Valve
E.	<b>0307116</b>	G-95	Relief Valve Seat
F.	***	***	Piston Body
G.	<b>0307210</b>	G-85	Filter O-ring
H.	<b>5307052</b>	G-21	Main Seat – 6 per package

### REPAIR KIT

Code No.	Part No.	Description
<b>3307128</b>	G-1011-A	Repair Kit includes Items: 2, 6, 7, B, C, E, G & H

For old style adjustable GEM flushometers use kit: G-1005-A  
 \*\*\* Indicates component is NOT available separately

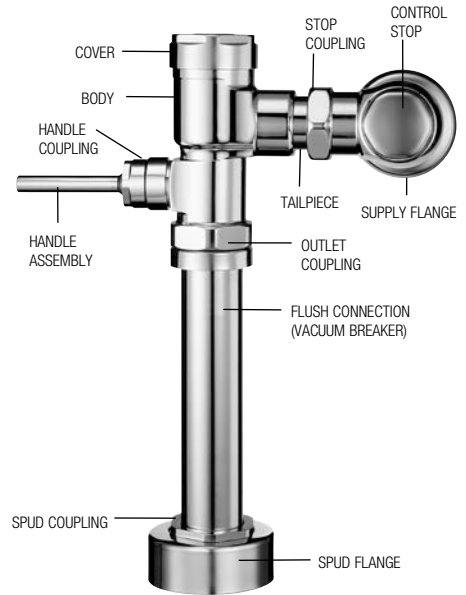
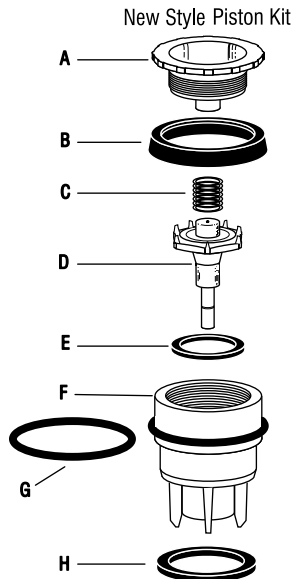

Manual Flushometers

## Gem•2® Flushometer

### REPAIR PARTS FOR OLD STYLE GEM FLUSHOMETERS (PRE-1985) Adjustable Cover

Item No.	Code No.	Part No.	Description
1.	—	G-24	CP Cover Screw – <b>OBSOLETE</b>
2.	—	G-23	CP Cover – <b>OBSOLETE</b>
	—	G-26	CP Cover for Bumper – <b>OBSOLETE</b>
3.	—	G-27	Bumper (12 per package) – <b>OBSOLETE</b>
4.	<b>0307058</b>	G-25	Cover Gasket (12 per package)
5.	—	G-4	RB Inside Cover – <b>OBSOLETE</b>
6.	—	G-6	RB Regular Screw – <b>OBSOLETE</b>
7.	—	S-26	Packing
8.	—	S-24	Packing Disc
9.	—	G-10	RB Packing Nut – <b>OBSOLETE</b>
10.	—	G-65	Gasket – <b>OBSOLETE</b>
11.	—	G-5	Gasket

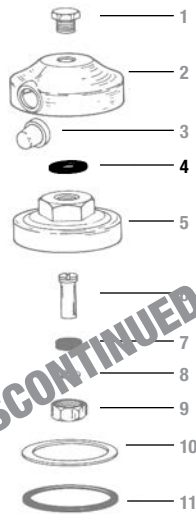

### SPUD COUPLING FOR OLD STYLE GEM FLUSHOMETERS (PRE-MAY, 2003)

Item No.	Code No.	Part No.	Description
1.	<b>0306125</b>	F-5-A	3/4" Spud Coupling
	<b>0305140</b>	F-5-A	1-1/4" Spud Coupling
	<b>0306146</b>	F-5-A	1-1/2" Spud Coupling

1A. SEE SLIP JOINT GASKETS AND RINGS TABLE ON BOTTOM, PAGE 30

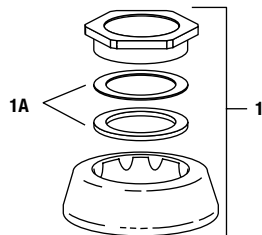

### HANDLE ASSEMBLY FOR OLD STYLE GEM FLUSHOMETERS (PRE-MAY, 2003)

Item No.	Code No.	Part No.	Description
1.	<b>0307100</b>	G-143-A	Handle Assembly – 6 per package
2.	<b>5307074</b>	G-50-A	Handle Repair Kit – 6 per package
3.	<b>5307065</b>	G-35	Handle Gasket – 48 per package
4.	<b>5302297</b>	B-39	Handle Seal – (12 per package)
5.	—	G-36	Handle Grip
6.	—	G-28	Handle Socket

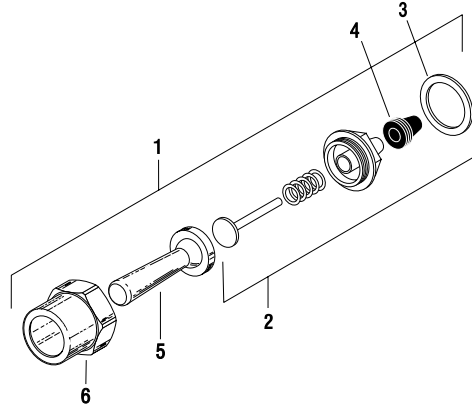

### REPAIR PARTS FOR OLD STYLE PISTON

Item No.	Code No.	Part No.	Description
12.	<b>0307105</b>	G-77	Piston Cover
13.	<b>0307106</b>	G-78	Molded Cup
14.	<b>0307113</b>	G-84	Spring
15.	<b>0307110</b>	B-81-A	Relief Valve
16.	<b>0307112</b>	G-83	Relief Valve Seat
17.	—	G-75	Closet Piston Body
	—	G-76	Urinal Piston Body
18.	<b>0307052</b>	G-21	Main Seat

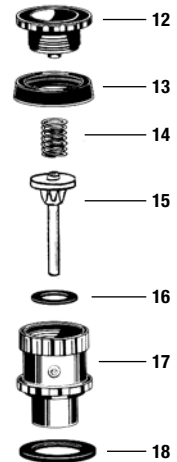

### PISTON KITS FOR OLD STYLE ADJUSTABLE GEM VALVES

Code No.	Part No.	Description	Piston Color	Barrel	Grooves
<b>0307044</b>	G-1002-A	Urinal	Black	Solid	0
<b>0307043</b>	G-1003-A	Water Closet	Black	Slotted	0

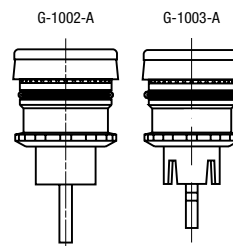

## Gem•2® Flushometer

### TROUBLESHOOTING GUIDE

**IMPORTANT:** The GEM flushometer is engineered for quiet operation. Excessive water flow creates noise, while too little water flow may not satisfy the needs of the fixture. Proper adjustment is made when plumbing fixture is cleansed after each flush without splashing water out from the lip AND a quiet flushing cycle is achieved.

Never open Control Stop to where the flow from the valve exceeds the flow capability of the fixture. In the event of a valve failure, the fixture must be able to accommodate a continuous flow from the valve.

**ATTENTION INSTALLERS:** With the exception of the control stop inlet, **DO NOT USE** pipe sealant or plumbing grease on any valve component or coupling! To protect the chrome or special finish of Sloan flushometers, **DO NOT USE** oiled tools to install or service these valves. Use our A-50 Super Wrench or other smooth-jawed wrench to secure couplings. Regulations for low consumption fixtures (1.6 gpf/6.0 Lpf closets and 1.0 gpf/3.8 Lpf urinals) prohibit use of higher flush volumes.

#### 1. Valve DOES NOT function.

- Control stop or main valve is closed. Open control stop or main valve.
- Handle assembly is worn. Install handle repair kit [G-50-A](#) or replace handle.
- Relief valve is worn and sticking in UP position. Replace piston.

#### 2. Insufficient volume of water to adequately siphon fixture.

- Control stop not open enough. Adjust control stop for desired delivery of water.
- Urinal piston parts inside a closet valve. Replace piston parts with proper closet piston.
- Low consumption valve installed on a non-low consumption fixture. Replace with proper piston kit.
- Inadequate volume or pressure at supply. Increase water pressure or supply (flow) to valve. Consult factory for assistance.

#### 3. Length of flush too short (short flushing) or valve closes off immediately.

- Piston assembly is not hand-tight. Screw the assembly hand-tight.
- Enlarged bypass orifice from corrosion or damage. Install NEW inside parts kit to correct problem and update flushometer.
- Urinal piston in closet flushometer. Replace piston with proper closet piston.
- Low consumption piston installed in non-low consumption fixture. Replace with proper piston kit.
- Handle assembly worn. Install handle repair kit [G-50-A](#).

#### 4. Length of flush too long (long flushing) or fails to close off.

- Piston is not seating properly or bypass orifice is clogged because of foreign material, or bypass orifice is clogged by an invisible gelatinous film from "over-treated" water. Disassemble the working parts and wash thoroughly. **NOTE:** Size of the orifice in the bypass is of utmost importance for the proper metering of water into the upper chamber of the valve. **DO NOT** enlarge or damage this orifice. Replace piston if cleaning does not correct problem.
- Line pressure has dropped and is not sufficient to force relief valve to seat. Shut off all control stops until pressure has been restored, then open them again.
- 3.5 gpf closet piston has been used in a 1.0 or 1.5 gpf urinal or on a 1.6 gpf toilet. Replace with proper piston.
- G-21 main seat is fouled with debris or is worn. Clean or replace main seat.

#### 5. Leaking at handle assembly.

- The [B-39](#) seal may have deteriorated. Install new [B-39](#) seal. **NOTE:** The seal will easily slide right onto the bushing if it is wet.
- Handle gasket has been omitted. Install [G-35](#) handle gasket or Sloan handle repair kit [G-50-A](#).
- Valve handle bushing is worn. Install Sloan handle repair kit [G-50-A](#).

### CARE AND CLEANING

**DO NOT USE** abrasive or chemical cleaners to clean flushometers as they may dull the luster and attack the chrome or special decorative finishes. Use **ONLY** mild soap and water, then wipe dry with clean cloth or towel.

While cleaning the bathroom tile, the flushometer should be protected from any splattering of cleaner. Acids and cleaning fluids can discolor or remove chrome plating.

**When assistance is required, please contact Sloan Technical Support at: 1-888-SLOAN-14 (1-888-756-2614).**

**For the Best Deals,  
Purchase Your  
Sloan Flush Valve  
Replacement Parts  
at Air Delights!**

**Shop Now!**

**SLOAN**

10500 SEYMOUR AVE. - FRANKLIN PARK, IL 60131  
PHONE: 1-800-9-VALVE-9 - FAX: 1-800-447-8329  
<http://www.sloanvalve.com>

**Air Delights**

11170 SW 5TH STREET, SUITE 100 - BEAVERTON, OR 97005  
PHONE: 1-800-440-5556 - FAX: 1-503-643-8224  
<http://www.airdelights.com> - [Customer\\_Service@AirDelights.com](mailto:Customer_Service@AirDelights.com)