

115/116 ES-S TMO

Description

Exposed, Sensor Activated Royal® Model Water Closet Flushometer with True Mechanical Override Button, for top spud bowls.

Flush Cycle

- Model 115-1.6 ES-S TMO Low Consumption (1.6 gpf/6.0 Lpf)
- Model 115 ES-S TMO Water Saver (3.5 gpf/13.2 Lpf)
- Model 116-1.6 ES-S TMO Low Consumption (1.6 gpf/6.0 Lpf)
- Model 116 ES-S TMO Water Saver (3.5 gpf/13.2 Lpf)

Specifications

Quiet, Exposed, Diaphragm Type, Chrome Plated Closet Flushometer with the following features:

- PERMEX® Synthetic Rubber Diaphragm with Dual Filtered Fixed Bypass
- OPTIMA® EL-1500-L Self-Adaptive Infrared Sensor with Indicator Light
- "Walk By" Delay of Eight (8) Seconds Prevents Unintentional Flushes
- User friendly three (3) second Flush Delay
- Non-Hold-Open True Mechanical Override
- Non-Hold-Open Integral Solenoid Operator
- Die Cast Wall Flange and Die Cast Sensor Plate with no visible Fasteners (for 2-gang Electrical Box)
- 1" I.P.S. Screwdriver Bak-Chek® Angle Stop with Free Spinning Vandal Resistant Stop Cap
- Adjustable Tailpiece
- High Back Pressure Vacuum Breaker Flush Connection with One-Piece Bottom Hex Coupling Nut, Spud Coupling and Flange for 1½" Top Spud
- Sweat Solder Adapter with Cover Tube and Cast Wall Flange with Set Screw
- High Copper, Low Zinc Brass Castings for Dezincification Resistance
- Non-Hold-Open Integral Solenoid Operator, Fixed Metering Bypass and No External Volume Adjustment to Ensure Water Conservation
- Flush Accuracy Controlled by CID Technology
- Diaphragm, Stop Seat and Vacuum Breaker molded from PERMEX Rubber Compound for Chloramine Resistance

Valve Body, Cover, Tailpiece and Control Stop shall be in conformance with ASTM Alloy Classification for Semi-Red Brass. Valve shall be in compliance with the applicable sections of ASSE 1037. Installation conforms to ADA requirements.

Variations

- TP** Trap Primer
- YG** Extended Bumper on Angle Stop (for seat with cover)
- YO** Bumper on Angle Stop (for open seat without cover)

Accessories

- EL-154** Transformer (120 VAC/24 VAC 50 VA)
- EL-342** Transformer (240 VAC/24 VAC 50 VA)

See Accessories Section and OPTIMA Accessories Section of the Sloan catalog for details on these and other Optima Flushometer variations.

Fixtures

Consult Sloan for Sloan brand matching fixture options.



Automatic

Sloan Optima® equipped flushometers provide the ultimate in sanitary protection and automatic operation. There are no handles to trip or buttons to push. The flushometer operates by means of an infrared sensor that adapts to its surrounding. Once the user enters the sensor's effective range and then steps away, the flushometer solenoid initiates the flushing cycle to flush the fixture.

Hygienic

User makes no physical contact with the flushometer surface except to initiate the Override Button when required. Helps control the spread of infectious diseases. 24-Hour Sentinel Flush keeps fixture fresh during periods of nonuse.

Economical

Automatic operation provides water usage savings over other flushing devices. Reduces maintenance and operation costs.

Practical

Solid state electronic circuitry assures years of dependable, trouble-free operation. The operational components of the flushometer are identical to a handle activated Royal® flushometer, proven by over 100 years of experience.

Warranty

3 year (limited)

Patent Pending

This space for Architect/Engineer approval	
Job Name _____	Date _____
Model Specified _____	Quantity _____
Variations Specified _____	
Customer/Wholesaler _____	
Contractor _____	
Architect _____	

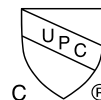

115/116 ES-S TMO



Description

Exposed, Sensor Activated Royal® Model Water Closet Flushometer with True Mechanical Override Button, for top spud bowls.

Flush Cycle

- Model 115-1.6 ES-S TMO Low Consumption (1.6 gpf/6.0 Lpf)
- Model 115 ES-S TMO Water Saver (3.5 gpf/13.2 Lpf)
- Model 116-1.6 ES-S TMO Low Consumption (1.6 gpf/6.0 Lpf)
- Model 116 ES-S TMO Water Saver (3.5 gpf/13.2 Lpf)

ELECTRICAL SPECIFICATIONS

Control Circuit

Solid State
24 VAC Input
24 VAC Output
8 Second Arming Delay
3 Second Flush Delay
24-Hour Sentinel Flush

Optima Sensor Range

Nominal 22" - 42" (559 mm - 1067 mm)
Self-adaptive Window: ± 10" (254 mm)

Solenoid Operator

24 VAC, 50/60 Hz

Transformer

Sloan Part #EL-154
120 VAC, 50/60 Hz Primary
24 VAC, 50/60 Hz Secondary
Class II, UL Listed, 50 VA.

Sloan Part #EL-342

240 VAC, 50/60 Hz Primary
24 VAC, 50/60 Hz Secondary
Class II, UL Listed, 50 VA.

WIRING DIAGRAM

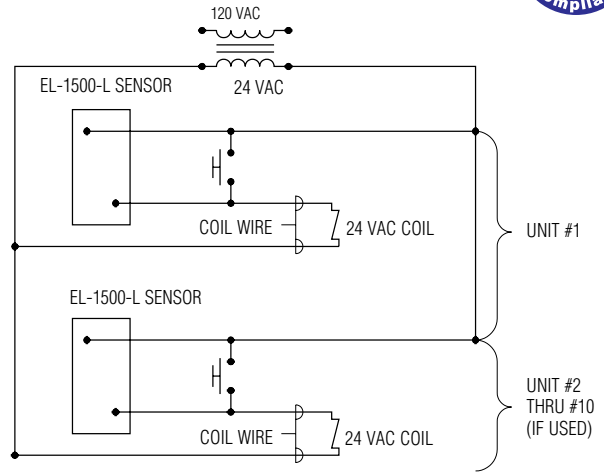

One Transformer serves up to ten (10) OPTIMA® Closet/Urinal Flushometers. Specify number of transformers required accordingly.

OPERATION

1. A continuous, invisible light beam is emitted from the Optima sensor.

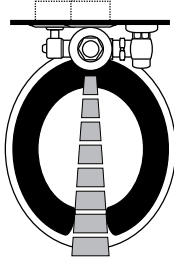

2. As the user enters the beam's effective range (22" to 42") the beam is reflected into the Optima scanner window and transformed into a low voltage electrical circuit. Once activated, the output circuit continues in a "hold" mode for as long as the user remains within the effective range of the sensor.

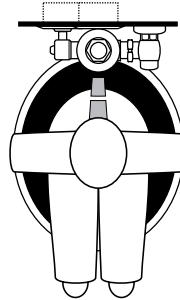

3. When the user steps away from the Optima sensor, the circuit waits 3 seconds (to prevent false flushing) then initiates an electrical "one-time" signal that operates the solenoid. This initiates the flushing cycle to flush the fixture. The circuit then automatically resets and is ready for the next user.

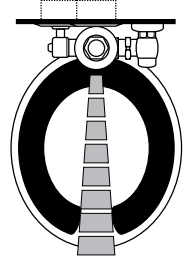

ROUGH-IN

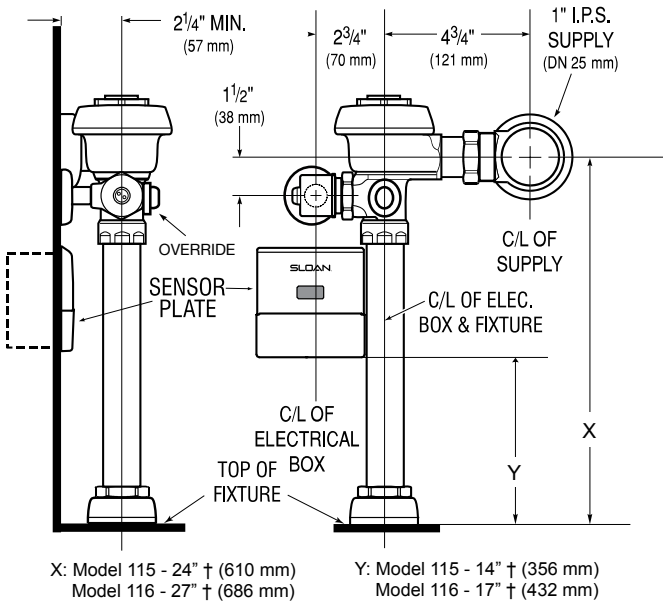

† Position of Sensor Box can be raised or lowered 1" (25 mm) if in conflict with Handicap Grab Bars.

ELECTRICAL BOX INSTALLATION

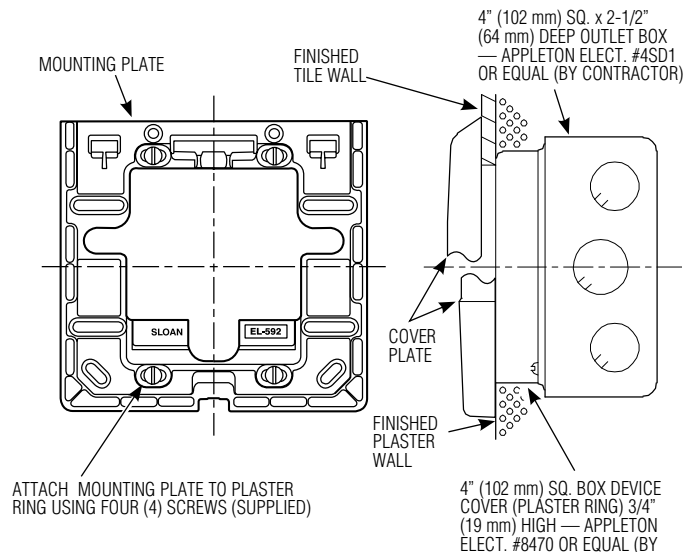

SLOAN

10500 SEYMOUR AVE. - FRANKLIN PARK, IL 60131
PHONE: 1-800-9-VALVE-9 - FAX: 1-800-447-8329
http://www.sloanvalve.com

Air Delights

11170 SW 5TH STREET, SUITE 100 - BEAVERTON, OR 97005
PHONE: 1-800-440-5556 - FAX: 1-503-643-8224
http://www.airdelights.com - Customer_Service@AirDelights.com